



THERM-X-TROL® SIZING CHARTS

Model Selection vs. Supply Pressure and Water Heater Size

RESIDENTIAL APPLICATIONS (UP TO 150°F)

Water Heater Size (gals.)	Static Supply Pressure (psi)		
	40	60	80
40	ST-5	ST-5	ST-5
50	ST-5	ST-5	ST-8
60	ST-8	ST-8	ST-8
80	ST-8	ST-8	ST-12
120	ST-12	ST-12	ST-25V

COMMERICAL APPLICATIONS (UP TO 180°F)

Water Heater Size (gals.)	Static Supply Pressure (psi)		
	40	60	80
40	ST-8	ST-8	ST-8
50	ST-8	ST-8	ST-12
60	ST-8	ST-12	ST-25V
80	ST-12	ST-25V	ST-25V
120	ST-12	ST-25V	ST-25V

BASED ON:

- THERM-X-TROL® pre-charge adjusted to equal static supply pressure.
- 150 psi T & P Safety relief valve

CODE LISTINGS:



NOTE: Models ST-5, ST-8, ST-12 & ST-25V are listed by IAPMO.

THERM-X-TROL®

CAPACITIES AND DIMENSIONS

Model Number	Total Volume Gallons	Dimensions		
		Diameter (A)	Height (B)	System Conn. (C)
ST-5	2.0	8"	12 5/8"	3/4" NPTM
ST-8	3.2	8"	15"	3/4" NPTM
ST-12	4.4	11"	15"	3/4" NPTM
ST-25V	10.3	15 3/8"	19 1/4"	3/4" NPTF

Maximum Allowable Working Temperature: 200 F
 Maximum Working Pressure: 150 PSIG
 Standard Factory Precharge: 40 PSIG Field Adjustable.
 Stainless Steel Connector.

Larger sizes available, up to 528 gallons
 Consult Therm-x-Trol brochure or visit www.amtrol.com

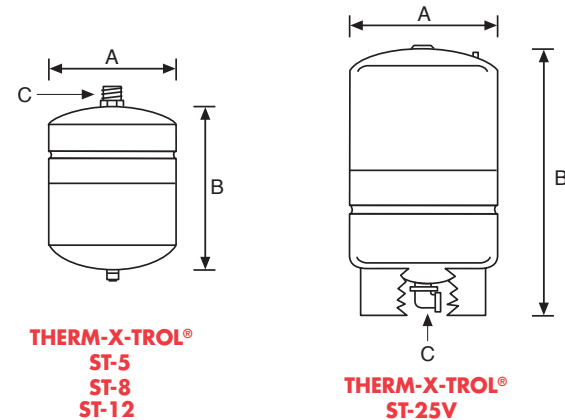

West Warwick, RI 02893

MC #: 8520 (02/10)